

DISCOVER

VOYAGER

TQMSM

TOTAL QUALITY MAINTENANCESM

GUARDIAN HP

DATATRAC

PRO-TORG

HUBODOMETER

SENTINEL



STEMCO[®]

A Higher Standard of Performance.SM

An EnPro Industries Company



Total Quality MaintenanceSM

A comprehensive guide to maintaining high quality wheel ends in your fleet.

COMPONENT DECISIONS:

- Hub Seal Selection 2-3
- Hub Cap Selection 4-5

SYSTEM SOLUTIONS:

- Platinum Performance Systems . . . 6-7
- Advantage Systems 8-9

INSTALLATION:

- Seal Installation
 - Guardian®/Guardian® HP 10
 - Voyager®/Discover® 11
 - Standard/Grit Guard® 12
 - Oil Analysis 13
- Hub Cap Installation and Troubleshooting 14-15
- Pro-Torq® Installation 16-17

BEARING ADJUSTMENT

- Bearing Removal/Installation . . 18-19
- TMC's Recommended Wheel Bearing Adjustment Procedures . . . 20
- Acceptable End Play and How to Measure It 21
- DataTrac® Installation 22

FAILURE ANALYSIS

- Identifying Seal Failure Modes . 23-29
- Tech Tips 30-31
- Limited Warranty 32

TQMSM Training Clinics/Certification . . 33

TQMSM

TOTAL QUALITY MAINTENANCESM

An all encompassing look at maintaining top quality wheel ends in your fleet



STEMCO[®]

A Higher Standard of Performance.SM

QS 9000 & ISO 9001

STEMCO - USA • P.O. Box 1989 • Longview, Texas 75606-1989 • (903) 758-9981 • 1-800-527-8492 • FAX 1-800-874-4297
STEMCO - Canada • 5900 Ambler Drive, Units 4 & 5 • Mississauga, ON L4W 2N3 • (905) 206-9922 • 877-232-9111 • FAX 877-244-4555

www.stemco.com



STEMCO is committed to a “Higher Standard of Performance” and increased customer value. We recognize the importance of providing customers with detailed product information, installation procedures and failure analysis. This **TQMSM** Manual was designed for this purpose, to assist in achieving a higher standard of performance within your operation.

What can **TQMSM** provide for your company?

- Reduced Maintenance Cost
- Less Equipment Down Time
- Reduced Liability Exposure
- Reduced Rework Cost
- Safer Operating Equipment
- Process Control
- Repeatable Quality

A wheel end is not a collection of parts functioning independently; it is a system of interacting components. Specifically, the hub seal, axle fastener, hub cap, bearings, and lubricant play an important role in the overall performance of the wheel end. Each component is interrelated and its performance affects the total system. Using STEMCO parts with fluid lubrication, your wheel end components will not only provide optimum individual performance, they will, together, form a world-class wheel end system.

Quality Components Working As An Integral Unit Supported By Trained Professionals.

As a result of four decades of experience in the trucking industry, STEMCO has accumulated product and process knowledge of wheel end systems that will benefit all maintenance professionals. **TQMSM** demonstrates how STEMCO products, designed to perform with standard hub and axle configurations combined with sound assembly procedures, can result in exceptional wheel end performance.

As trucking technology has advanced, STEMCO has responded to the needs of the industry. At STEMCO, state-of-the-art equipment duplicates exact road conditions to test seal products and to insure their durability and performance. This **TQMSM** Manual is designed to maximize your investment in today’s technologically advanced components, thereby helping the transportation industry achieve the goal of **Total Quality MaintenanceSM**.



STEMCO Hub Seal Selection

STEMCO has provided the trucking industry with reliable hub seals for more than 40 years. Throughout our history, we have recognized the need for tougher, longer life seals that meet the performance, design and price requirements related to selecting the right seal for any fleet. To meet that need, STEMCO has engineered a menu of sealing options designed to meet the varying performance expectations of each fleet, all in an effort to maximize performance and value.



Discover[®]

HIGH PERFORMANCE
LONG LIFE



Voyager[®]

BRAKE JOB-TO-
BRAKE JOB
DURABLE



Guardian[®]
HP

AMERICAN TRAILER
STANDARD
LONG LIFE



GRITGUARD[®]

RUGGED & DURABLE



HUB SEALS



Discover® is designed for the long haul carrier seeking high performance components. The Discover® Seal is an excellent choice for fleets running outboard-mounted drums that allow brake changes without seal replacement. The long life characteristics of this seal, proven in testing that exceeds competitive products' performance by five times, make it the industry choice for performance driven fleet managers.



The Voyager® Seal is designed for regional route trucks, city delivery and coach applications. Rugged design, simple installation and proven performance make Voyager® the right choice for fleets looking for a superior brake job-to-brake job seal. In the everyday stop-and-go traffic environment these vehicles experience, the Voyager® Seal is the best value.



The Guardian® HP is the standard seal for trailer and axle original equipment manufacturers. The axle installation is durable and unique, and has proven successful for more than 25 years. Today, its enhanced features offer improved cost-per-mile performance. With simple one-step axle installation, Guardian® HP is the seal of choice in the trailer industry.



Always rough and ready, Grit Guard® has endured more than forty years of dirty, unfriendly road environments that destroy wheel end components. So with this forty year plus track record of performance, Grit Guard® endures where others fail, and is still the choice for fleets working in grueling environments.

STEMCO Hub Cap Selection

STEMCO, the industry leader in hub caps, has developed a comprehensive offering of hub caps for all applications. To meet the performance, design and price requirements of today's national and international fleets, STEMCO has developed a menu of hub cap options for both oil and grease applications. The product line has evolved into product specific technology developed to eliminate contaminants in abusive environments.



The traditional aluminum series 340 and 343 provide durability with the trademark red plug to allow venting of the hub cap. Using cast aluminum for constructing the hub cap body prevents warpage and provides superior durability and heat dissipation properties. The trucking industry recognizes STEMCO hub caps as the benchmark.



For grease applications, the 342 series Dirt Exclusion Hub Caps provide the same 340 casting without a side fill plug, plus a solid window with a sintered metal vent for venting purposes. To further support grease wheel ends, STEMCO developed the 352 series Solid Aluminum Hub Caps with a duckbill vent inserted in the face of a solid hub cap.

STEMCO Stamped Steel grease hub caps are manufactured from 14 gage steel and have a protective yellow chromate plating with a clear lacquer coating for additional protection from corrosion. For synthetic base grease like Mobilith SHC#007™, use the vented 340-5096 version cap. For petroleum base grease use the non-vented 340-5097 cap.



HUB CAPS

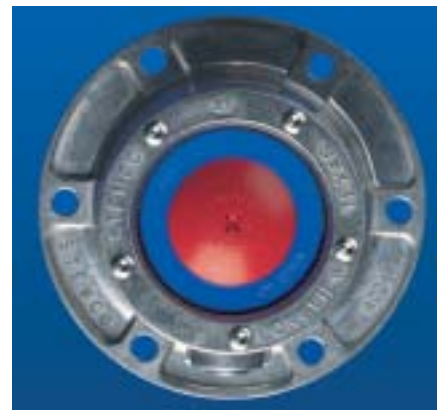

STEMCO PSI hub caps are available in both oil and grease for several popular applications. The oil hub caps have a side fill plug and a standard window with oil fill lines. The grease hub caps do not have a side fill plug and incorporate a gray opaque window with no markings. The PSI tee fitting and flapper valve are to be installed in the center of the hub cap and are available from PSI as a part of the PSI System.

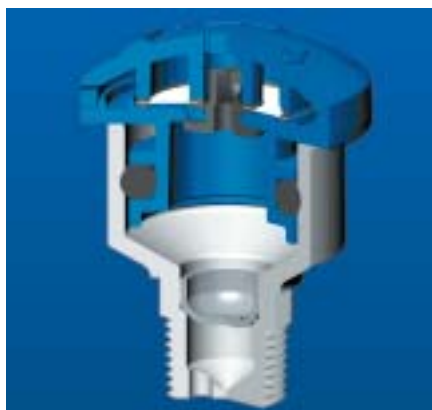

Sentinel® Technology provides an unmatched filtering system to eliminate contamination of lubricant from grime, dirt or water. STEMCO provides four options to put Sentinel® Technology to work for you:

The Sentinel® Hub Cap provides tamper-proof system for maximum protection and maintenance-free performance.

Integrated Sentinel® Hub Caps integrate the sentinel® features into the window with fewer components and greater wheel end visibility.

The Sentinel® ESP (Extended Service Plug) and Sentinel® ESP Filtered Vent allows economical retrofitting of wheel ends and drive axles with the benefits of STEMCO's exclusive Sentinel® Technology.

STEMCO Platinum Perf

PLATINUM PERFORMANCE SYSTEM™

PLATINUM PLUS PERFORMANCE SYSTEM™

The STEMCO Platinum Performance Systems combine premium products that work as a system to ensure the most comprehensive wheel end performance available. All of the significant failure modes found in a typical wheel end have been addressed. High performance STEMCO components are used to specifically enhance three critical areas – sealing, lubricant integrity, and bearing life due to accurate bearing adjustment. By addressing these critical performance areas with advanced technology components, customers are able to use standard hubs and axles for wheel ends that provide outstanding performance at the lowest cost in the industry.

STEMCO now offers a choice of two long-life systems with extended warranty coverage, plus the assurance of a dramatic increase in performance that will lower maintenance costs and protect wheel end investment.

Four Technologically Advanced Products



Guardian® HP Seal

Long-life, axle-installed seal features a high performance sealing lip, superior contamination exclusion and self-lubricating thrust pad.

Discover®

Or

Long-life, high performance hub-installed seal features a unitized design using a high temperature elastomeric co-polymer sealing element combined with Teflon®.

Pro-Torq® Advanced Axle Spindle Nuts

Controls axial motion, holding bearing end play at .001" to .003." That means wheels track truer for longer tire life, extended wheel seal and bearing life and more accurate wheel end sensor monitoring on ABS.



Sentinel® Hub Cap

The heart of the Platinum Performance System™ The Sentinel® tamper-proof hub cap technology provides an unmatched filtering system for wheel ends to eliminate contamination of the lubricant from grime, dirt, or water.

Or

Integrated Sentinel® Hub Cap

Integrates the Sentinel® Technology directly into the hub cap with fewer components and greater wheel end visibility.

Heavy Duty Bearings

STEMCO is able to supply your wheel bearing needs by providing matched bearing sets offering safety, reliability and performance from a single source. You can be assured that each STEMCO bearing conforms to our stringent quality and performance standards. Every Platinum Matched set optimizes the performance that fleets expect.



Performance Systems

PLATINUM PERFORMANCE SYSTEM™

3 YEAR LIMITED WARRANTY

- Guardian® HP or Discover®
- Pro-Torq® Nut
- Sentinel® or Integrated Sentinel® Hub Cap
- Platinum Matched Bearings (optional)
- Available for OEM Spec or Fleet Retrofit

PLATINUM PLUS PERFORMANCE SYSTEM™

5 YEAR LIMITED PARTS & LABOR WARRANTY

- Guardian® HP or Discover®
- Pro-Torq® Nut
- Sentinel® or Integrated Sentinel® Hub Cap
- Heavy Duty Bearings
- Available for OEM Spec Only

STEMCO Long-life Wheel End Systems Offer:

- **Simplicity** – Proven, known wheel end design.
- **Low Cost** – No costly equipment changes.
- **Durability** – uses high performance components for sealing, bearings, bearing adjustment and lubricant protection.
- **Field Serviceable** – Standard hub, axle, lubricant and bearings.
- **Reliability** – Address traditional wheel end failure areas with high performance technology products working as a system.



STEMCO Advantage

ADVANTAGE **SYSTEM**™

The exclusive STEMCO Advantage System™ provides today's most advanced protection available for your wheel end. For the unbeatable combination of a high performance wheel end and reduced maintenance costs, STEMCO now offers fleets the option of specifying the Advantage Plus System™. This OE-installed, unitized hub consists of premium STEMCO components, and provides a 5-year limited warranty on all STEMCO parts.

The Advantage System™ includes the Discover® Seal, STEMCO's premium hub-installed, unitized design seal with a new high temperature sealing element; Pro-Torq® Advanced Axle Spindle Nuts that provide consistent bearing settings for extended wheel seal and bearing life; and the proven Sentinel® Hub Cap, with a filtering system that eliminates contamination. All hubs and bearings in the Advantage System™ are cost efficient industry standard components, making the Advantage System™ a flexible and affordable wheel end solution.

Advantages of OEM Installed Systems

- 5-year Limited Warranty When Specified on OEM Builds
- Field Serviceable Components
- Industry Standard Components Combined to Reduce Maintenance and Improve Cost Efficiency
- Address the Three Most Critical Aspects of the Wheel End: Sealing Ability, Bearing Adjustment and Lubricant Integrity



Photo Courtesy of Lufkin Trailers



Systems

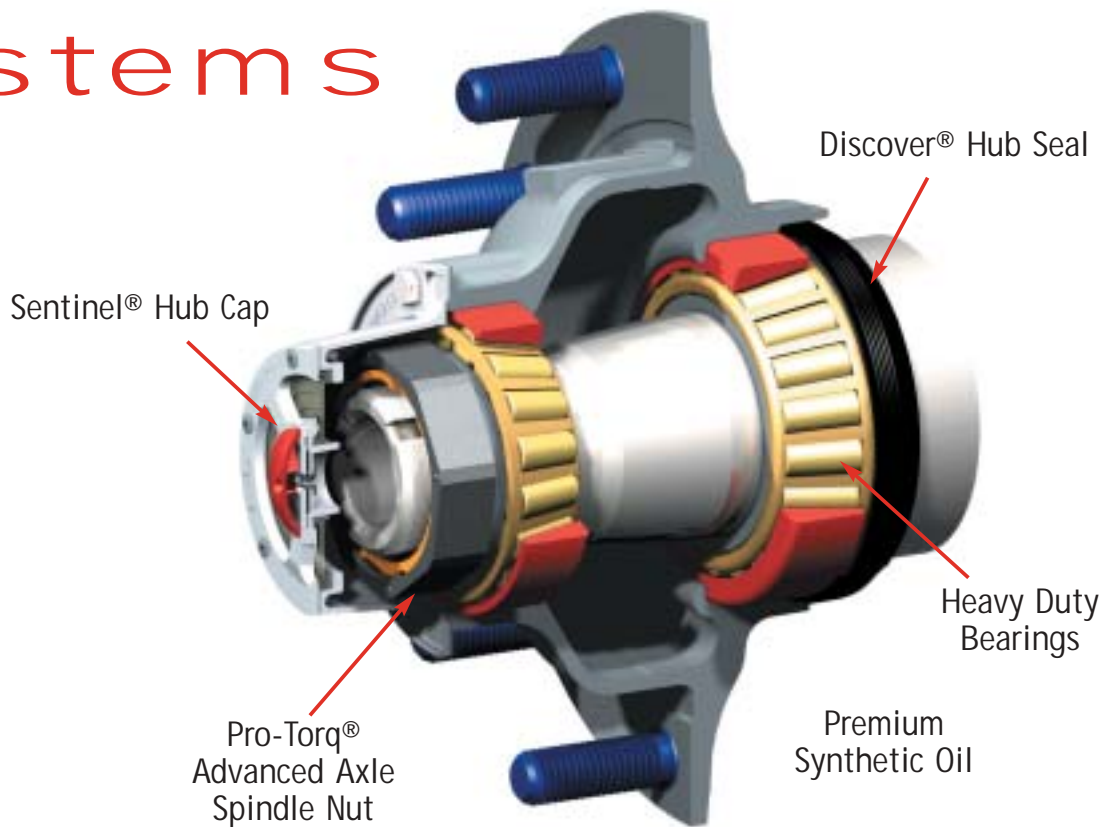

A comprehensive approach to maximize wheel end performance using **Technologically Advanced Products**

- Unitized Hub-Installed Discover® Seal with a New High Temperature Sealing Lip Pre-installed by OEM
- Pro-Torq® Advanced Axle Spindle Nut - Pre-loaded Bearing Adjustment Optimizes Seal and Bearing Running Environment
- Sentinel® Hub Cap - Superior Tamper-Proof Hub Cap Technology Provides an Unmatched Filtering System for Wheel Ends to Virtually Eliminate Contamination of the Lubricant from Dirt, Grime or Water
- Standard Hubs and Bearings
- Premium Synthetic Oil - SAE 50 wt. Transmission Oil

ADVANTAGE PLUS SYSTEM™

- Now Add STEMCO Bearings to Enhance Your Warranty Coverage
- 5-year Limited Parts & Labor Warranty



Guardian[®] and Guardian[®] HP Seal Installation

- Step 1** Remove all burrs from the hub bore and spindle. Thoroughly clean the entire wheel cavity. Apply a thin layer of No. 2 sealant to the OD of the spindle shoulder. Place the seal assembly on the spindle so the words “Oil Bearing Side” are exposed to the oil. **[Photo 1]**
WARNING: Do not install the seal into the hub bore.
- Step 2** Using the recommended STEMCO Universal Axle Tool, drive the seal assembly on until the tool bottoms against the shoulder. **[Photo 2]** Make sure the ring is flush with the shoulder. Wipe away any excess sealant.
- Step 3** Dip the inner bearing in oil and place on the spindle. *NOTE: The OD of the seal must be coated with a thin coat of oil. NOTE: When using grease, pre-pack the inner bearing before placement into the hub.*
- Step 4** With the wheel mounted on a wheel dolly, carefully push the wheel onto the spindle until it contacts the seal. **[Photo 3]** Dip the outer bearing in oil and place it on the spindle. *NOTE: When using grease, pre-pack the inner bearing before placement into the hub.* Tighten the inner spindle nut hand tight and remove the wheel dolly.
- Step 5** Tighten the inner nut to 200 ft/lbs. **[Photo 4]** Rotate the wheel several times and then back-off nut one full turn. Make final bearing adjustment according to TMC recommended bearing adjustment procedure. Install the appropriate axle fastener.
- Step 6** Install the hub cap with a new gasket and fill the cavity with lubricant until the proper oil level is indicated on the window. On drive axles, be sure the differential oil level is high enough (manufacturer’s recommended level) to ensure oil flow through the tube to the wheels. It is recommended to jack-up one side and then the other until flow starts. Make certain the breather plug is clear. Recheck steers and trailers to insure proper fill levels.

Voyager® and Discover® Hub-Seal Installation

- Step 1** Remove all burrs from the hub bore and spindle. Thoroughly clean hub cavity and spindle.
NOTE: Do not apply any sealant to the spindle shoulder.
- Step 2** With the wheel in horizontal position, pre-lube the inner bearing and place it into the bearing cup.
[Photo 1] NOTE: When using grease, pre-pack the inner bearing before placement into the hub.
- Step 3** Place the seal on the recommended STEMCO Installation Tool, with the correct head, so that the words “Air Side” face into the tool. Place the tool (with the seal correctly mounted in the tool head) over the hub bore. Use a 3 to 5 pound hammer to drive against the end of the tool. Drive seal into bore until complete bottoming is assured.
[Photo 2] Remove Tool. Apply a thin layer of lubricant on the ID surface of the seal.
NOTE: Do not apply lubricant to the OD of the seal.
- Step 4** With the wheel mounted on a dolly, carefully align the bore with the spindle. **[Photo 3]** Gently push the wheel assembly onto the spindle to the proper position. Fill the hub cavity with lubricant until it runs over the outer bearing cup. Coat the outer bearing with lubricant and place it on the spindle and into the bearing cup.
NOTE: When using grease, pre-pack the outer bearing before placement into the hub.
- Step 5** Assemble the inner nut and tighten it to 200 ft/lbs. **[Photo 4]** Rotate the wheel several times and then back-off nut one full turn. Make final bearing adjustment according to TMC recommended bearing adjustment procedure. Install the appropriate axle fastener.
- Step 6** Install the hub cap with a new gasket and fill the cavity with lubricant to the proper level. On drive axles, be sure the differential oil level is high enough (manufacturer’s recommended level) to ensure oil flow through the tube to the wheels. It is recommended to jack-up one side and then the other until flow starts. Make certain the breather plug is clear. Recheck steers and trailers to insure proper fill levels.





Standard/ Grit Guard® Seal Installation

- Step 1** Remove all burrs and thoroughly clean the spindle. Apply a thin layer of No. 2 sealant to the OD of the spindle shoulder. Place the axle ring on the spindle.
- Step 2** Using the recommended STEMCO Universal Axle Tool, drive the axle ring on until the tool bottoms against the spindle shoulder. [Photo 1] Make certain the axle ring is flush with the shoulder. Wipe away any excess sealant.
- Step 3** Remove all burrs from the hub bore and thoroughly clean the entire wheel cavity.
- Step 4** With the wheel in horizontal position, pre-lube the inner bearing and place it into the bearing cup. [Photo 2] *NOTE: When using grease, pre-pack the inner bearing before placement into the hub.*
- Step 5** Apply a thin layer of No. 2 sealant to the OD of the seal and position the seal in the hub. Using the recommended STEMCO Universal Hub Tool held in a vertical position, drive the seal into the seal bore until it is bottomed-out. [Photo 3] Check the clearance between the bearing cone and seal (at least 1/32" is required).
- Step 6** With the wheel mounted on a dolly, carefully align the bore with the spindle. [Photo 4] Gently push the wheel assembly onto the spindle to the proper position. Pre-lube the outer bearing and push it into the bearing cup.
- Step 7** Assemble the inner nut and tighten it to 200 ft/lbs. [Photo 5] Rotate the wheel several times and then back-off nut one full turn. Make final bearing adjustment according to TMC recommended bearing adjustment procedure. Install the appropriate axle fastener.
- Step 8** Install the hub cap with the new gasket and fill the cavity to the proper oil level as indicated on the window. On drive axles, be sure the differential oil level is high enough (manufacturer's recommended level) to ensure oil flow through the tube to the wheels. It is recommended to jack-up one side and then the other until flow starts. Make certain the breather plug is clear. Recheck steers and trailers to insure proper fill levels.

The Visual Crackle A New Twist to an Old Technique

Purpose: Moisture in lubricating oils is a primary contaminant that leads to degradation of lubricant base-stock and additives, and it also corrodes component surfaces and accelerates wear due to reduced fluid film strength. The visual crackle test is a simple field method to detect and roughly quantify the presence of moisture in these fluids.

Method: The crackle-test is a simple test to identify the presence of free and emulsified water that is suspended in oil. Water is the most harmful element to the machine as well as to the oil. The method is as follows:

1. Achieve surface temperature on a hot plate of 300° F (135° C). Be sure to always use the same temperature.
2. Violently agitate oil sample to achieve homogenous suspension of water in oil.
3. Using a clean dropper, place a drop of oil on the hot plate.

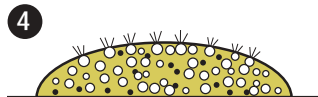
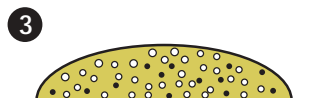
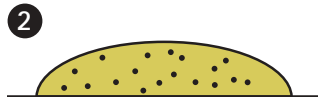

Observable Results:

1. If no crackling or vapor bubbles are produced after a few seconds, no free or emulsified water is present.
2. If very small bubbles (0.5 mm) are produced but disappear quickly, approximately 0.05-0.1% water is present.
3. If bubbles approximately 2 mm are produced and gather at the center of oil spot and then enlarge to about 4 mm and disappear, approximately 0.1 to 0.2% water is present.
4. For moisture levels above 0.2%, bubbles may originate at approximately 2-3 mm and then grow to 4 mm, with the process repeating once or twice. For even higher moisture levels, violent bubbling and audible crackling may result.

Limitations:

1. The method is non-quantitative.
2. Hot plate temperatures above 300° F induce rapid scintillation that may be undetectable.
3. The method does not measure the presence of chemically dissolved water.

Safety Considerations:

1. Protective eyewear is suggested.
2. Long sleeves are suggested.
3. Test should be performed in a well-ventilated area.

Equipment Required:

1. Hot plate capable of achieving and maintaining 300° F surface temperature.
2. Paint shaker (or equivalent) for oil agitation.
3. Oil dropper tube or lab syringe.

Applicable Standards: None

Interferences:

Refrigerants and other low boiling-point suspensions may interfere. Different base stocks, viscosities, and additives will exhibit varying results. Certain synthetics, such as esters, may not produce scintillation.

Printed with permission from
Noria Corp., Tulsa, OK

www.oilanalysis.com



Hub Cap Installation

The hub cap endures constant physical abuse from the elements and internal factors that can affect its characteristics both visually and functionally. The TQMSM Manual will provide helpful information about installation and lubrication, as well as help in troubleshooting problems. Additionally, examples of potential hub cap failures are pictured in the Failure Analysis section.

Proper Hub Cap Installation Procedures

- Step 1** Check the mounting surface of the hub, making sure to clean off old gaskets and sealant. Also, check for any burrs or imperfections that might prevent a proper gasket seal.
- Step 2** Make sure all components are free of any dirt or grit.
- Step 3** Always install the hub cap with a new gasket.
- Step 4** Split washers are recommended to lock the flange bolts in place.
- Step 5** Initially tighten the hub cap (see bolt tightening sequence below) and finally torque to the recommended specification as noted on Page 15.
- Step 6** For the threaded Pro-Par caps, lightly lubricate the threads and O-ring and install the hub cap. Refer to the torque specifications on Page 15 for the recommended torque value for threaded hub caps.
- Step 7** For oil applications, fill to the recommended level and re-check after the lube has had adequate time to establish its final level.

Window Kit Replacement Procedures

- Step 1** Remove the old window ring using a #8 Torx driver.
- Step 2** Thoroughly clean the hub cap and window ring leaving the window ledge free of oil and the mounting surface of the window ring clean and free of any old gasket material.
- Step 3** Place the new window gasket in the hub cap casting, and insert the new window with the window ring and window ring gasket in place.
- Step 4** It is recommended that screws be replaced with new ones. Once the screws have been started and pulled down, begin tightening with a cross hatch pattern to evenly distribute the load. Refer to the Torque Specifications chart on Page 15 for the proper torque. It is recommended that hand tools be used for this procedure, as power tools may over-torque the screws and damage the threads.
- Step 5** The hub cap is now ready for installation.

RECOMMENDED BOLT TIGHTENING SEQUENCE

4 BOLT

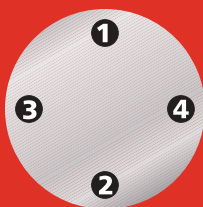

5 BOLT

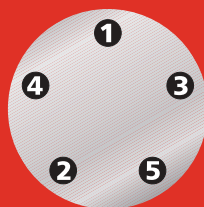

6 BOLT

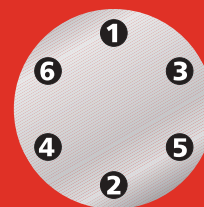

and Troubleshooting

Frequently Asked Questions

- Q. Should the hub cap be packed with grease?**
- A.** A small amount of grease may be added to the hub cap before installation. Do not cover the vent mechanism with grease. See Page 26 for more detail. For additional information on lubrication fill procedures for hub caps, refer to TMC publication RP 631.
- Q. How tight should the flange bolts be?**
- A.** Refer to the Hub Cap Torque Specifications below.
- Q. Is it OK to use an impact to mount the hub cap?**
- A.** It is suggested that hub cap bolts be tightened with hand tools to prevent possible warping or breakage of the hub cap flange. Refer to the Torque Specifications below for the recommended torque value.
- Q. Is venting required for all applications?**
- A.** It is suggested that the wheel assembly be vented to allow the hub to vent pressure and relieve vacuum when using oils and synthetic greases. Only with heavy packing grease will the wheel end properly operate without venting.
- Q. Why do my hub caps have a build-up on the inside of the sight glass?**
- A.** This build-up is a slow process caused by the additives present in some lubricants. Removal is impossible; however, replacement window kits are available.

TROUBLESHOOTING GUIDE	
PROBLEM	POSSIBLE SOURCES OR CAUSES
Water Contaminated/ Milky Oil	High pressure washing, flooded loading docks (Note: See Oil Crackle Test on Page 13).
Bulged/Melted Windows	Check for low lube level, high heat caused from improperly adjusted bearings, high heat caused from improperly adjusted brakes.
Leaking Gaskets	Improper torque of flange bolts, gouged mounting surface (hub cap flange/hub face), no gasket, reuse of gasket.
Leakage from Red Fill Plug	Make sure the oil level is not in an overfilled condition, and check the vent hole to make certain it is not plugged. High heat and resulting pressure may also contribute to leakage.

HUB CAP TORQ SPECS			
THREADED HUB CAPS			
XXX-4075	100 ft/lbs		
340-4975	50-60 ft/lbs		
340-4976	50-60 ft/lbs		
640-0003	50-60 ft/lbs		
HUB CAP COMPONENTS			
359-6032	#8 Torx Screw	25 in/lbs	
359-5984	3/8" Mag Plug	5-9 ft/lbs	
359-5985	3/8" Pipe Plug	5-9 ft/lbs	
HUB CAP MOUNTING BOLTS			
1/4"	8-12 ft/lbs	3/4"	24-28 ft/lbs
5/16"	12-16 ft/lbs	7/8"	26-30 ft/lbs
3/8"	16-20 ft/lbs		
7/16"	18-22 ft/lbs	6MM	8-12 ft/lbs
1/2"	20-24 ft/lbs	8.5MM	12-16 ft/lbs

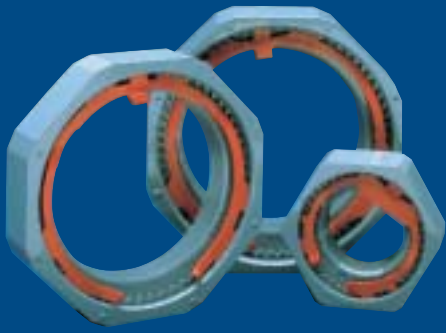

Pro-Torq® Spindle Nuts

Why?

- Safety
- Extended Seal Life
- Extended Bearing Life
- Extended Tire Life

How?

- Wheel Bearing Adjustment Accuracy of .001" to .003" End Play
- Infinite Locking Positions
- Twice the Number of Threads to Firmly Hold Bearings
- Controlled Axial Motion-Avoids Extremes of Pre-load and Excessive Bearing End Play

Ask any mechanic...

Does excessive end play or over tightening of critical engine components affect the life expectancy of the engine?

Well, it makes sense that the same answer applies to wheel ends. Precisely designed seals, bearings and hubs are only as good as the precision with which they are assembled as an integral unit. That's where the STEMCO Pro-Torq® Spindle Nut comes in.

Proper bearing adjustment could be the singularly most critical aspect of wheel end performance. The effect on all wheel end components, seals, bearings and tires is highly impacted by improperly adjusted bearings. Properly installed, the Pro-Torq® Spindle Nut is designed to deliver precise wheel bearing adjustment.

PRO-TORQ®

Installation Procedure and Wheel Bearing Adjustment



- 1 Use a screwdriver to carefully pry the keeper arm from the undercut groove on each side until the keeper is released.



- 5 Use a torque wrench and torque the nut to the specifications indicated on the chart (on Page 17) while rotating the wheel.



- 6 Back the nut off one raised face mark. Use the chart (on Page 17) to determine the proper back-off for your application.



- 10 Inspect the inner keyway tang to make sure it does not contact the bottom of the keyway.



- 11 This procedure will consistently produce a bearing setting of .001" to .003" end play. Use a dial indicator to verify the bearing end play. Reference Page 19.

FAQs - Common Causes and Solutions

- Q.** Is there a problem with the keeper hitting the bottom of the keyway or the flat of the spindle?
- A.** If contact exists, contact STEMCO Customer Service @ 1-800-527-8492.
- Q.** Is a washer required between the Pro-Torq® Nut and the outer bearing?
- A.** The bearing contact surface is hardened, therefore a washer is not required. One exception is a Ford 12,000# SIFCO steer axle.
- Q.** What if the teeth in the Pro-Torq® Nut do not match-up with the keeper after the final adjustment?
- A.** By very slightly loosening the nut, the teeth will engage the keeper.

More specific bearing adjustment procedures with standard adjustment nuts are addressed on Page 18.



2 Thread the nut onto the axle until hand tight against the bearing.



3 Use a torque wrench to torque the nut to 200 ft-lbs while rotating the wheel to seat the bearing.



4 Back the nut off until it is loose.



7 Install the keeper by inserting the keeper tab into the undercut groove of the nut and engage the keyway tang in the axle keyway. Rotate the keeper into position so that the inner keeper tang fits into the axle keyway.*



8 If the inner tang does not line-up with the keyway, back the nut off slightly until it does. Using a screwdriver, compress and insert the keeper arms, one at a time, into the undercut groove. The orange painted side of the keeper must be facing out.



9 Inspect the installation to make sure the keeper tab and the keeper arms are fully seated into the undercut groove.

ADJUSTING TORQUE AND BACKOFF		
Part Numbers	Adjusting Torque	Backoff
Trailer Axle Nut 447-4723 447-4724	100 ft-lbs	1/8 turn
Trailer Axle Nut 447-4743	100 ft-lbs	1/4 turn
Steering Spindle Nut 448-4836 448-4839 448-4864	100 ft-lbs	1/4 turn
Steering Spindle Nut 448-4837	100 ft-lbs	1/3 turn
Drive Axle Nut 449-4904 449-4973 449-4974 449-4975	100 ft-lbs	1/8 turn

WARNING! Failure to follow these instructions could cause the wheel to come off and cause bodily injury. Failure to back-off the nut will cause the bearing to run hot and be damaged.

*For Steering Spindle Nuts 448-4836, 448-4839 & 448-4864: Align the flat of the keeper with the milled flat on the spindle and insert the single keeper tab into the undercut groove of the nut. Insert keeper tab with bent legs facing out. Engage the mating teeth. Compress and insert the keeper arms, one at a time, into the undercut groove with a screwdriver.

TOOLS REQUIRED FOR INSTALLATION			
Part Numbers	(3/4" Drive) Socket Req'd	Owatonna Co. Ref. Part No.	Euclid Int'l Ref. Part No.
Trailer Axle Nut 447-4723 447-4724	4 ¹³ / ₁₆ " 8 point	1941	E-1597
Trailer Axle Nut 447-4743	3 ³ / ₄ " 8 point	1925	E-1925
Steering Spindle Nut 448-4836 448-4837	2 ¹ / ₂ " 6 point	1921	E-1921
448-4839	2 ⁵ / ₈ " 6 point	1922	E-1922
448-4864	3" 6 point	1906	E-1906
Drive Axle Nut 449-4904	4 ¹ / ₈ " 6 point	1915	E-1915
449-4973	4 ³ / ₈ " 8 point	1917	E-1917
449-4974	3 ³ / ₄ " 8 point	1925	E-1925
449-4975	3 ³ / ₄ " 8 point	1925	E-1925

Note: Ford application 12,000 lbs SIFCO Steer Axle requires OEM inner washer to be installed prior to installation of PRO-TORQ® Nut system.

WARNING! Failure to follow these instructions could cause the wheel to come off and cause bodily injury. The PRO-TORQ® Spindle Nut is sold as an assembly with the keeper in place. **DO NOT** attempt to place the nut on the spindle or tighten or loosen the nut on the spindle while the keeper is locked inside the nut. Doing so may deform the keeper and allow the nut to unthread during operation.



Heavy Duty Bearings and Platinum™ Matched Bearing Set Features and Benefits

- Value Added Bearing Program. Through strategic alliances and strong global procurement, STEMCO Bearings meet the changing needs of today's market. STEMCO Bearings are the right mix of Performance, Convenience and Value.
- Consolidated Wheel End Components Provider. The same company that provides High Performance STEMCO Wheel Seals, Pro-Torq Precision Adjusting Nuts and Hubcaps, can supply your wheel bearing needs; providing safety, reliability and performance from a single source.
- STEMCO Quality Bearings. Our worldwide network of manufacturing plants is held to the highest quality standards by STEMCO and meets the ABMA specifications for bearing life calculations.
- OEM Quality Bearings from STEMCO. The world's leading OEM Truck Manufacturers are standard with the bearings from our QS9000 and ISO 9001 Certified factories.

Features and Benefits

- Large, easy-to-read LCD display makes data retrieval simple and accurate. Additional flexibility of trip and life readings for precise data collection and management.
- Numbers automatically position upright for easy verification of mileage.
- Compact size makes it easy to mount and dismount tires without removing the DataTrac® from the wheel.
- No moving parts, provides improved reliability and durability for the most demanding vocational applications. Each unit is marked with a unique serial number providing additional security and data control.
- Long-life battery allows for 4 year, 500,000 mile warranty.
- Calibrated to perform on more than 2,500 specific tire models and sizes to ensure reliable mileage information.

DataTrac®

With more than 1 million miles of testing, the DataTrac® shows unparalleled accuracy.



- The STEMCO DataTrac® is an indispensable tool for scheduling maintenance, determining lease charges, validating guarantees, and calculating costs per mile.
- STEMCO will pre-set your DataTrac® with the mileage data you require for a nominal charge.
- Uses existing STEMCO mounting brackets or Hubodometer® hub caps.

Bearing Removal and installation

Removal



Step 1 Remove hub/wheel assembly from vehicle in accordance with recommended practices.

Step 2 Remove inboard and outboard bearing cones and set aside for inspection.

Step 3 Using a mild steel drift or cup driver, carefully drive out the bearing cups.

- Caution should be used when driving bearing cups, as drifts and other tools can damage bearings.
- Drifts can damage hub bearing bores. Be careful not to score bores while removing cups, especially when using aluminum hubs.

Inspection



Step 1 Inspect the hub bearing bores and shoulders for damage. The bores should be smooth and free from scoring, burrs, indications of cup spinning, or other forms of damage. Remove any burrs or raised areas using emery cloth, a file, or other appropriate tool.

Step 2 Measure the bearing cup bore and compare to manufacturer specifications.



Step 3 Inspect bearing cups and cones for damage. Bearings should be free from chips, contamination, and signs of excessive wear or excessive heat. Refer to bearing damage analysis literature for identifying possible bearing issues.

Step 4 Inspect axle spindle bearing journals for any signs of damage or excessive wear. Remove any raised areas or burrs using emery cloth, a file, or other appropriate tool.

Step 5 Journals should be measured and compared with manufacturer specifications.

Installation

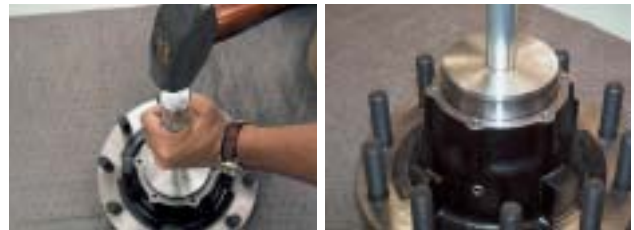

Step 1 Thoroughly clean bearing cups and cones prior to installation.

- Do not use compressed air to spin bearing rollers as injury may result if cage does not retain the rollers.

Step 2 Lightly coat the outside of bearing cups with oil.

Step 3 Using a cup driver, carefully drive bearing cups into hub bearing bores. Be sure to drive cup firmly against cup shoulder in hub.

- If a cup driver is not available, a mild steel drift can be used to install bearing cups.

- Caution should be used when driving bearing cups, as drifts and other tools can damage bearings.

- NEVER use a bearing cone to drive a bearing cup. This can damage the bearings and cause premature failure.

Step 4 Use a feeler gauge to check for gaps between cup and shoulder.

Step 5 Inspect the bearing cups to ensure no damage occurred during installation.

Step 6 Lubricate bearing cones according to recommended practices and proceed with installation of wheel assembly.

STEMCO Endorses TMC's Recommended Wheel Bearing Adjustment Procedure

Proper wheel bearing adjustment is critical to the performance of wheel seals and other related wheel end products. For that reason, we are proud to be a part of TMC's Wheel End Task Force.

We are happy to bring these standards to you in the form of this technical guide. Working together in this way, STEMCO helps keep your rigs rolling. **For Technical Support, call: 1-800-527-8492.**

The following bearing adjustment recommendation was developed by TMC's Wheel End Task Force (RP 618). It represents the combined input of manufacturers of wheel end components.

STEP 1.

Bearing Lubrication:

Lubricate the wheel bearing with clean lubricant of the same type used in the axle sump or hub assembly.

STEP 2.

Initial Adjusting Nut Torque:

Tighten the adjusting nut to a torque of 200 ft-lbs. while rotating the wheel.

STEP 3.

Initial Back-Off:

Back the adjusting nut off one full turn.

STEP 4.

Final Adjusting Nut Torque:

Tighten the adjusting nut to a final torque of 50 ft-lbs. while rotating the wheel.

STEP 5.

Final Back Off:

AXLE TYPE	THREADS PER INCH	FINAL BACK-OFF
Steer (Single Nut)	12	1/6 Turn*
	18	1/4 Turn*
Steer (Double Nut)	14	1/2 Turn
	18	1/2 Turn
Drive	12	1/4 Turn
	16	1/4 Turn
Trailer	12	1/4 Turn
	16	1/4 Turn

*Install cotter pin to lock axle nut in position.

STEP 6.

Jam Nut Torque:

AXLE TYPE	NUT SIZE	TORQUE SPECIFICATIONS
Steer (Double Nut)	Less Than 2 ⁵ / ₈ "	200-300 ft-lbs
	2 ⁵ / ₈ " And Over	300-400 ft-lbs
Drive	Dowel Type Washer	300-400 ft-lbs
	Tang Type Washer	200-275 ft-lbs
Trailer	Less Than 2 ⁵ / ₈ "	200-300 ft-lbs
	2 ⁵ / ₈ " And Over	300-400 ft-lbs

STEP 7.

Acceptable End Play:

Refer to Page 21 for measuring end play.

Bearing Adjustment Procedure for Single Castellated Nut

1. Torque the Castellated Nut to 200 ft/lbs.
2. Back the nut off 1/2 to 1 full turn and rotate wheel assembly.
3. Re-torque Castellated Nut to 75 ft/lbs while wheel assembly is rotated.
4. Lock Castellated Nut in place with a new cotter pin through one of the two holes drilled in the axle. If at 75 ft/lbs you are not on a hole, back the nut off to the closest hole and lock in place with the cotter pin.
5. Due to Castellated Nut configuration, variation in bearing adjustment can be significant.
6. Always check end play after final adjustment and lock down.

Acceptable End Play and How to Measure It

- Step 1** Using a magnetic base, mount the dial indicator on the spindle end, making sure the hub face is clean and free of gasket material.
- Step 2** Adjust the arm of the dial indicator, setting the plunger tip of the indicator on the machined face of the hub at the 12 o'clock position. The plunger should be set-up so that it is parallel to the axis of the spindle. When positioning the indicator tip, ensure that the indicator has adequate range of travel for proper measurement. Set the indicator to zero.
- Step 3** Grasp the wheel/hub assembly at the 3 o'clock and 9 o'clock positions. Pull the wheel end assembly outward while oscillating the wheel approximately 45°. While continuing to pull, stop oscillating and read the indicator.
- Step 4** Push the wheel assembly inward while oscillating. While continuing to push, stop oscillating and read the indicator.
- Step 5** Read bearing end play as total indicator movement.

Acceptable end play is .001" to .005" as measured with a dial indicator as per TMC's Recommended Bearing Adjustment Procedure.

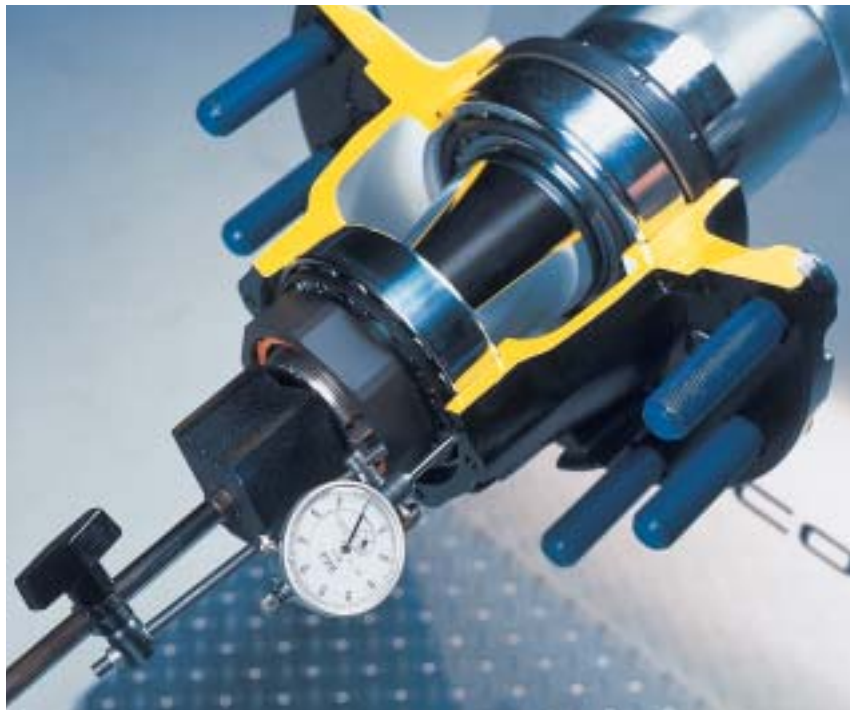

To achieve consistent and accurate end play in the .001"-.003" range without dial indicating, use the Pro-Torq® Spindle Nut.

DataTrac® Installation instructions

HOW IT WORKS

DataTrac® is an advanced mileage counter that relies on Earth's gravity for counting wheel revolutions. The DataTrac® unit monitors its orientation to Earth's gravitational pull and uses this reference to recognize and count revolutions.

INSTALLING THE UNIT

In order to prevent inadvertent counting during shipment, a new DataTrac® unit will be delivered in "Ship Mode." **To wake the device**, shake it vigorously for 4 seconds. The display will turn on and a timer will begin counting down. Install the DataTrac® unit before the timer reaches zero (approximately 2 minutes). This will prevent counts induced by handling vibrations. **A unit should never be installed on a wheel without first waking it up.**

READING THE DISPLAY

The display will turn on when the vehicle is at rest. Numbers will automatically orient to read upright. This is also indicated by the icon display, e.g. mile, km, acre. The mileage reading is always in the same direction as the icon.

In order to conserve power the display turns off at night and any time a vibration is detected, e.g. when the vehicle is moving. As soon as all vibration or motion stops the display will reactivate in about 5 seconds. To activate the display at night, shine light directly at the device to trigger the sensor.

DISPLAY MODES

The DataTrac® unit comes equipped with two display modes: LIFE and TRIP. To toggle the display between LIFE and TRIP Modes, use the palm of your hand to cover the round bubble on the face of the unit for at least 1 second, and then uncover it. If the unit is in bright sunlight, the bubble may have to be covered with your palm to block more light from reaching the sensor. Only part numbers 600-1XXX (mi) and 600-0XXX (km) are equipped with a TRIP feature. TRIP mode is displayed with tenths resolution and is indicated by display of the TRIP icon.

To reset the TRIP display, toggle between LIFE and TRIP Modes 5 times, quickly. Note that the unit cannot toggle faster than every 1.5 seconds.

LOW BATTERY INDICATOR (LOBAT)

When the battery reaches a minimum limit, a "LOBAT" icon will appear below the mileage reading. The unit should be replaced at this point. If the battery is allowed to completely discharge, mileage will not be lost.

CERTIFICATIONS

This unit complies with European EMI (CE) regulations as noted on front cover by the E11 marking.

PRODUCT LIMITATIONS

It is important to note that this unit is designed to recognize vibrations and accelerations common to wheel rotation, therefore, it will not count accurately when held in a person's hand, which allows movement in any direction. Furthermore, this unit should not be used as a rotating shaft counter for machinery, unless the machine shaft rotates slower than 1250 RPM and has a slow acceleration profile similar to a wheel end. At all times the unit should rotate about an axis perpendicular to gravitational forces.

This unit contains a Lithium-Thionyl Chloride battery and should be disposed of according to local regulations. The battery contains less than 1 gram of lithium and is therefore classified as a non-hazardous product. Lithium-Thionyl Chloride batteries contain no poisonous materials and do not present environmental hazards when properly disposed of.

Wake DataTrac® by shaking vigorously for 4 seconds.

Display will turn on and timer will begin to count down.

Install DataTrac® before timer reaches zero to prevent counts induced by handling.

Display turns on when the vehicle is at rest.

Display turns off at night or when vibration is detected (vehicle moving) to conserve energy.

Display turns on at night by shining a light directly on the device to trigger the sensor.

LIFE mode shows mileage without tenths.

TRIP mode shows mileage with tenths and TRIP icon.

Toggle between LIFE and TRIP: Cover the round bubble for 1 second and then remove hand. To reset TRIP, repeat 5 times quickly.

DataTrac®

Failure Analysis

A Key Element of TQMSM

Determining the cause of component failure can be difficult. The following photographs and descriptions are primary failure modes and their typical causes and/or solutions. While this TQMSM Manual will address numerous installation procedures and recommendations, it is also important to understand why products fail in order to correct potential factors that may cause these failures.

In addition to the information which follows, STEMCO would also like to offer additional sources of product evaluation and solutions to problems:

1. Contact STEMCO Customer Service to request Technical Support at **1-800-527-8492**.
2. Contact the District Sales Manager in your area.
3. Ship failed parts to STEMCO's Warranty Department for evaluation.
 - A. Select a representative sample of mated seals and rings or other products.
 - B. Wipe off excess oil, but **DO NOT** wash the parts in solvent.
 - C. Attach a tag if parts are mates, showing vehicle mileage, component mileage, wheel position, oil type, vehicle ID and installation date/removal dates.
 - D. Ship parts to: **STEMCO**
300 Industrial Blvd.
Longview, Texas 75602
Attn: Warranty Department
 - E. STEMCO will provide you a written report of the analysis.





Burr in Hub

Deep axial cuts on the OD of this seal created a leak path for oil. Proper inspection and clean-up of the hub can eliminate this problem.



Burr on Spindle

Deep axial cuts on the ID of this axle ring created a leak path for oil. Proper inspection and clean-up of the spindle can eliminate this problem.



Cocked Seal

The high friction area shown on the left in one position on the seal face and the gouged metal in the axle ring are indicators of a seal being installed in a cocked position. The result can be increased heat and pumping of oil caused by the eccentric run out of the seal.



Bumped Spindle

Heavy facial damage is an indication that the seal incurred a hard impact with the spindle during the docking procedure. The result is damaged internal components that prevent proper sealing. The docking procedure is very important, as the critical elements of the seal are in close proximity to the spindle.



Incorrect Installation Tool

The seal on the right was installed with an incorrect tool, causing the outer case to bend. Note the clearance gap on the seal to the left and the lack of this critical characteristic on the right. This damage is detrimental to the proper function of the seal.



Ring with Rust in Groove

This axle ring shows signs of rust, indicating that water was present in the lubricant. Investigation to determine the source of the water will prevent this occurrence in the future.



Rubber Peeled Back

The condition of the rubber OD of this Guardian® Seal was caused by a hub being improperly docked. The mis-alignment of the hub and seal caused the rubber OD to be peeled back. Follow Guardian® installation instructions to prevent this problem. A clean, rust free seal bore is also necessary.



Poor Lip

Normal performance of seals will not destroy the seal lip as seen here. This condition occurs as a result of excessive and abrasive contaminants in the wheel end. Proper clean-up and inspection of bearings will prevent this.



Damaged Hubodometer® Face

Facial impact or damage caused when changing tires can result in a cracked cover and potential internal damage.



Hubodometer® with Bent Stud

This condition is the result of a tire/rim assembly being dropped or resting on the Hubodometer®. The resulting damage destroys the ability of the Hubodometer® to perform properly.



Hubodometer® with Ridge at Base of Stud

A ridge or groove at the base of the stud indicates the Hubodometer® was not tight on the bracket and was spinning in the mounting hole of the bracket.



Bulged Window on Hub Cap

The bulged, discolored appearance of this hub cap window is an indication that the wheel has experienced high temperatures resulting from improperly adjusted bearings, low lubrication or possibly brake problems.



Impact to Hub Cap

Damage to hub caps such as this is due to heavy impact and can cause leakage under the window.



Overtorque of Flange Nuts

Damage to the flange of this hub cap occurred when the flange nuts were overtightened and proper tightening procedure was not used to evenly fasten the hub cap in place. Use of air impacts with excessive torque settings may also contribute to this problem.





Punctured Hub Cap Casting

This damage is most often caused by tire/wheel assemblies being dropped on the hub cap during removal. The result is heavy loss of oil.



Pro-Torq® - No Threads

Failure to remove the orange keeper before removing the Pro-Torq® Nut will result in damaged threads to both the nut and the spindle. Overtorque of the Pro-Torq® Nut will also result in stripped threads.



STEMCO Universal Tool System

Recognizing that most seal failures can be traced to improper installation, STEMCO has designed Universal Hub and Axle Tools to make the procedure simpler and precise. Compromising proper installation by using anything other than the specified STEMCO tool can be very costly.



1. Contamination

- Appearance - Dents or impressions in rollers or raceways.
- Causes - Presence of foreign material in wheel.
- Remedies - Leave bearings in their original packages until time of installation. Install bearings in clean environment (hands, tools, etc.). Make sure hub is free from contamination.



2. Corrosion

- Appearance - Staining, rusting, and/or pitting of bearing surfaces.
- Causes - Moisture (water) in wheel end.
- Remedies - Replace lubricant. Use caution to make sure water is not introduced into the wheel end.



3. Inadequate or Improper Lubrication

- Appearance - Partial or large area welding, scoring, signs of excessive heat, metal to metal contact.
- Causes - Use of improper lubricant or inadequate quantity of lubricant. Overloading of bearings or excessive pre-load can exhibit similar appearance to inadequate lubrication.
- Remedies - Follow manufacturer recommendations for proper lubricant fill quantities and use of appropriate lubricants. Be sure to follow manufacturer recommendations for proper bearing adjustment.



4. Spalling / Fatigue

- Appearance - Missing material from surfaces of bearing rolling elements or raceways.
- Causes - Normal fatigue (life) of bearings, contamination, or excessive loading.
- Remedies - If due to normal life, replace bearings. If cause is other than normal life, correct per recommendations for that failure mode.

Procedure for Using Semi-Fluid Lubricants with Sentinel® and Stamped Steel Hub Caps

SENTINEL® HUB CAPS

Recent interest in the use of semi-fluid lubricants prompted STEMCO to develop a procedure for adding lubricant to the Sentinel® Grease Hub Caps to provide added lubrication to the outer bearing. Adherence to this procedure should result in longer wheel end life and improved performance. Addition of lubricant should be completed as follows:

1. Holding the hub cap as shown in Figure 1, fill the lower side of the hub cap until level with the inner edge of the mounting flange and the edge of the vent mechanism. Table 1 provides the approximate volume of lubricant necessary for each hub cap part number. **DO NOT COVER THE VENT MECHANISM WITH LUBRICANT!** This will result in “filming” or seepage of lubricant from the vent onto the external face of the hub cap during initial operation.
2. Install the hub cap quickly to prevent spilling the lubricant.

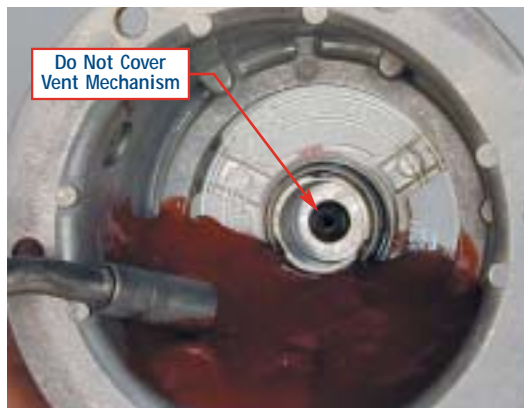

Figure 1 Fill Level for Semi-Fluid Lubricant

Sentinel® Application	Approximate Fluid Ounces of Lubricant
349-4009	3.5
349-4013	3.5
349-4046	2.9
349-4075	7.2
349-4095	2.4
349-4195	6.8

Table 1 Lubricant Quantity for Each Application

STAMPED STEEL HUB CAPS

STEMCO Stamped Steel Hub Caps are zinc dichromate plated to provide corrosion protection and a superior finish. STEMCO recommends that all stamped steel hub caps be internally coated with a thin layer of lubricant prior to installation. Coating should be performed as follows:

1. Using a clean brush or your hand (Figure 2), wipe the inner surfaces of the stamped steel hub cap with a thin layer of lubricant until all areas are covered as shown. **DO NOT COVER THE VENT MECHANISM WITH LUBRICANT!** This will result in “filming” or seepage of lubricant from the vent onto the external face of the hub cap during initial operation, and may clog the vent in some cases.
2. For this purpose, NLGI grade 2 or 3 hard pack greases are the preferred lubricants, as they do not flow and will maintain coverage of the plating on the internal surface of the hub cap.
3. Install the hub cap per normal installation practices.
4. Use this procedure on all STEMCO Stamped Steel Hub Caps.

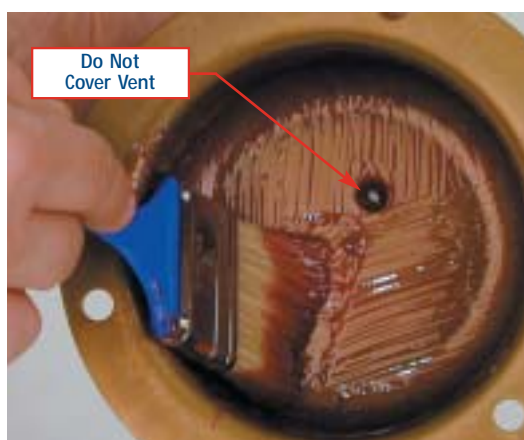

Figure 2 Coat the Inside of Stamped Steel Hub Caps.

STEMCO Tech Tips

STEMCO Tech Tips are developed to provide detailed information about particular products and/or procedures. These Tech Tips are available from STEMCO by requesting the numbers noted below. Visit www.stemco.com for periodic Tech Tip updates and/or new Tech Tips.

STEMCO Tech Tips	
Tech Tip #	Technical Information
3	Moisture Ejector Installation
5	Guardian® HP Wheel Seals-Proper Installation
6	Guardian® HP Wheel Seals-Lubricant Compatibility
8	Installation for Pro-Torq® P/N's 449-4974 & 449-4975
11	Procedure for Using Semi-fluid Lubricants
12	Improved Universal Axle Tool
13	Sentinel® Products & Internal Vacuum
14	448-4836/448-4837 Keeper Removal Procedure
15	392-9112 & 392-9130 Grit Guard® Sets Commonality
23	Pro-Torq® Keeper Replacement Interval
24	Sentinel® ESP Filtered Vent
26	Installation For Pro-Torq® Part Number 448-4837

Lubrication

With the vast array of wheel end configurations and operating variables, STEMCO recommends following manufacturer's recommendations for lubricant selection. Additionally, STEMCO endorses **The Maintenance Council's** recommended practice **RP 631** (Recommendations for Wheel End Lubrication) and **RP 624** (Lubricant Fundamentals), available from TMC.



STEMCO® Standard Components 1 YEAR WARRANTY

STEMCO warrants to Buyer that all components sold will be free from defects in material and workmanship. This warranty is limited to components installed on vehicles licensed for on-highway use under normal use and service. This warranty extends for a period of one year from the date of manufacture.

The Buyer's exclusive remedy under this warranty shall be the repair or replacement of STEMCO components, but not the cost of removal or installation. STEMCO reserves the right to require that all warranty claim components are available and/or returned for review and evaluation. STEMCO shall not be liable for any claim, whether arising from breach of contract or warranty or claims of negligence or negligent manufacture, in excess of the purchase price. In no event shall STEMCO be liable for special, incidental, indirect, or consequential, or collateral, losses or damages of any kind.

This limited warranty is in lieu of all other warranties or conditions, expressed or implied, including any implied warranty of merchantability or fitness for particular purpose. This is the only warranty offered by STEMCO and no STEMCO employee or representative is authorized to extend additional warranty terms on behalf of STEMCO.

3 YEAR WARRANTY

PLATINUM PERFORMANCE SYSTEM™

- TRAILER - Unlimited Mileage
- TRACTOR - Limited 250,000 Mile Warranty

5 YEAR WARRANTY



- TRAILER - Unlimited Mileage
- TRACTOR - Limited 250,000 Mile Warranty Platinum Performance System PLUS Limited 350,000 Mile Warranty for Advantage Systems

500,000 MILE WARRANTY

HUBODOMETER®

GUARANTEED OVER-LIFE-OF-TIRE ACCURACY

The STEMCO Hubodometer® is warranted for 500,000 miles when installed in accordance with its specifications.

4 Year / 500,000 MILE WARRANTY

DataTrac®

DataTrac® is warranted for 4 years / 500,000 miles when installed in accordance with its specifications.

WARRANTY



May STEMCO Have the Opportunity to Provide On-site TQMSM Training to Your Fleet Professionals?

TQMSM Training. The answer to reducing wheel end failures is a phone call away. STEMCO is ready to help you build consistent, dependable wheel ends by providing professional hands-on training.

Many causes of wheel end failure can be found in this manual, but our TQMSM training and mechanic certification program will add the final complement to Total Quality Maintenance.SM

Contact your STEMCO Representative for more details on this program and scheduling TQMSM training.

STEMCO Quality Products



STEMCO[®]

A Higher Standard of Performance.SM

QS 9000 & ISO 9001

STEMCO - USA

P.O. Box 1989 • Longview, Texas 75606-1989
(903) 758-9981 • 1-800-527-8492 • FAX 1-800-874-4297

STEMCO - Canada

5900 Ambler Drive, Units 4 & 5 • Mississauga, ON L4W 2N3
(905) 206-9922 • 877-232-9111 • FAX 877-244-4555

www.stemco.com

STEMCO, Hubodometer, Pro-Torq, Sentinel, Guardian HP, Discover, Voyager, Sentinel ESP, and DataTrac are trademarks of STEMCO LLC

©2004 STEMCO LLC

Printed in the USA
574-0139 (10-538) Rev 3-04